

## 30mm Diameter, Single-Turn, Carbon Industrial Panel Controls



### Features

- 30mm diameter, single-turn industrial panel controls
- Carbon film element
- Linear or audio tapers
- Single, tandem and triple units, single shaft; dual unit, dual shaft
- SPST or SPDT switch with 1A or 3A rating
- Shaft lock models
- Metal shaft and bushing
- Panel mount only
- Right angle ear-lug terminals
- 6mm diameter shafts in slot, flat or round end styles
- Standard 15mm or 20mm shaft length

### Specifications

#### Electrical

**Standard Resistance Range** . . . . . B = 100Ω to 2MΩ  
 A,C = 1kΩ to 2MΩ

**Resistance Tolerance** . . . . . ±10% standard

**End Resistance** . . . . . 3Ω max.

**Resistance Taper** . . . . . B = linear; A = CW audio (logarithm);  
 C = CCW audio (logarithm)

**Peak Noise (C.R.V.)** . . . . . 3% or 3Ω, whichever is greater

**Power Rating** . . . . . Ratings below at +40°C, 0 watt at +85°C

Taper	R ≤ 10kΩ	10kΩ < R ≤ 50kΩ	50kΩ < R ≤ 300kΩ	R > 300kΩ
B	1.0W	0.8W	0.6W	0.4W
A,C	0.8W	0.6W	0.3W	0.2W

**Maximum Input Voltage** . . . . . B = 500VDC; A,C = 350VDC  
 or power rating, whichever is smaller

**Insulation Resistance** . . . . . 100MΩ minimum at 1,000VDC

**Dielectric Strength** . . . . . 1,000VAC, 1 minute

**Adjustment Travel** . . . . . 280° ± 10°

#### Mechanical

**Mechanical Travel** . . . . . 300° ± 5°

#### Shaft Torque

Single Unit . . . . . 51 to 306 gf•cm (0.707 to 4.242 oz•in)  
 Other Units . . . . . 51 to 510 gf•cm (0.707 to 7.070 oz•in)

**Stop Strength** . . . . . 10.2 kgf•cm (141.4 oz•in) max.

**Mounting Nut Torque** . . . . . 15 kgf•cm (207.94 oz•in) max.

**Solderability** . . . . . 235°C, 5 seconds

**Marking** . . . . . Model type, taper, resistance code,  
 shaft type, terminal identification, date code

#### Environmental

**Temperature Range** . . . . . -10°C to +85°C

**Temperature Characteristics** . . . . . +85°C, 30 minutes  
 without load  
 R ≤ 10kΩ → ΔT/R ≤ ±6%  
 10kΩ < R < 1MΩ → ΔT/R ≤ ±10%  
 R ≥ 1MΩ → ΔT/R ≤ ±15%

**Load Life** . . . . . +40°C, 1,000 hours with rated load  
 ΔT/R ≤ ±10%

**Moisture and Load Life** . . . . . +40°C, 90-95% RH,  
 500 hours with rated load  
 R < 100kΩ → ΔT/R ≤ -10% ~ +15%  
 R ≥ 100kΩ → ΔT/R ≤ -10% ~ +20%

**Thermal Shock** . . . . . -10°C ~ +85°C,  
 5 cycles without load  
 ΔT/R ≤ ±10%

**Vibration** . . . . . 10-55Hz, 1.5mm amplitude,  
 3 directions, 2 hours each  
 ΔT/R ≤ ±2.5%

**Soldering Heat Resistance** . . . . . 350°C, 3.5 seconds  
 ΔT/R ≤ ±2%

**Rotational Life** . . . . . 15,000 cycles (500 cycles for shaft lock  
 models only) without load  
 ΔT/R ≤ ±7%

#### Standard Rotary Switches

**Switch Rating** . . . . . 110VAC, 1A or 3A, SPDT or SPST

**Contact Resistance** . . . . . 0.05Ω max.

**Operating Torque** . . . . . 1,530 gf•cm (21.21 oz•in) max.

**Operating Life** . . . . . 10,000 cycles with rated load

R = Total Resistance Value; ΔT/R = Total Resistance Change



**RV30YNME & RV30YNMF**

**Panel Mount, Single Unit with Switch, Single Shaft**  
**Right Angle Ear-Lug Terminals, Rear Exit Lug Terminals for 1A or 3A SPDT Switch**

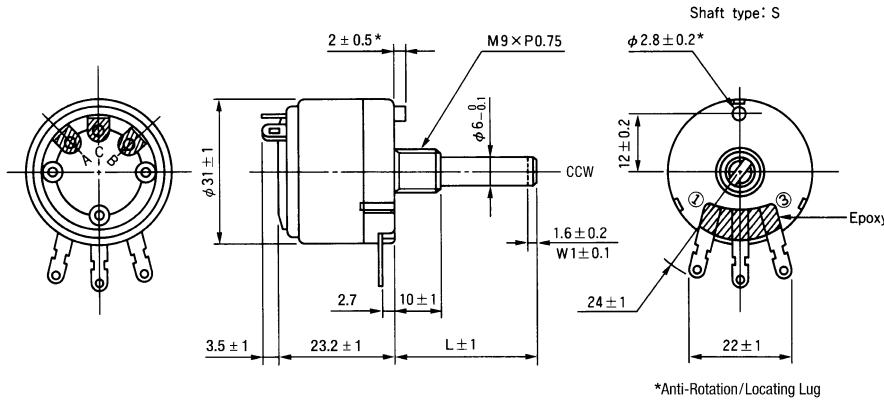

**Recommended Panel Mounting Holes**

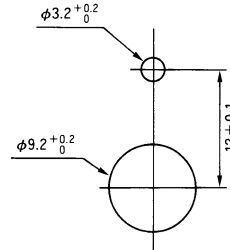

**RV30YG**

**Panel Mount, Ganged Tandem Unit, Single Shaft**  
**Right Angle Ear-Lug Terminals on Each Unit**

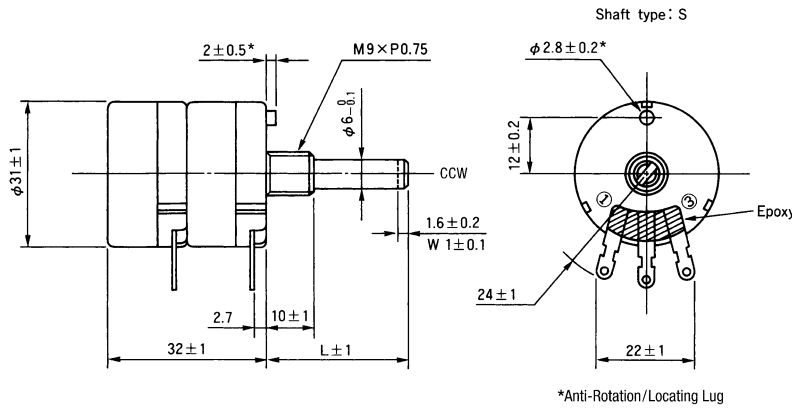

**Recommended Panel Mounting Holes**

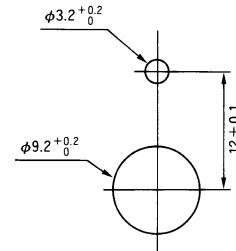

**RV30YGL**

**Panel Mount, Ganged Tandem Unit, Single Shaft with Shaft Lock**  
**Right Angle Ear-Lug Terminals on Each Unit**

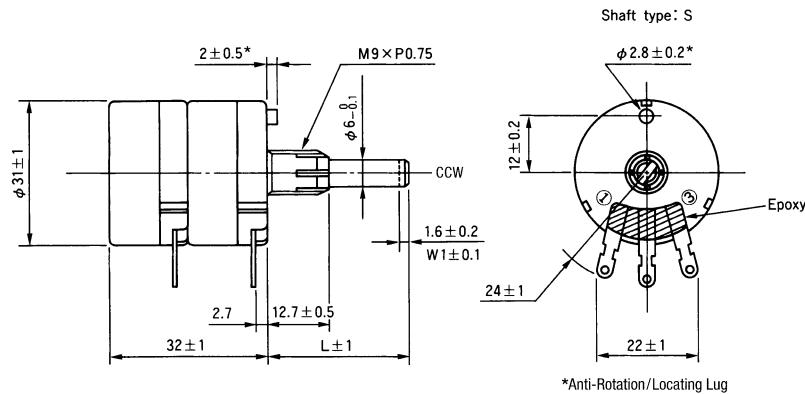

**Recommended Panel Mounting Holes**

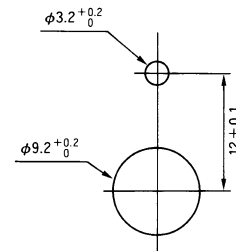

**RV30YGSE, RV30YGSF, RV30YGME & RV30YGMF**  
**Panel Mount, Ganged Tandem Unit with Switch, Single Shaft**  
**Right Angle Ear-Lug Terminals on Each Unit**  
**Rear Exit Lug Terminals for 1A or 3A SPST or SPDT Switch**

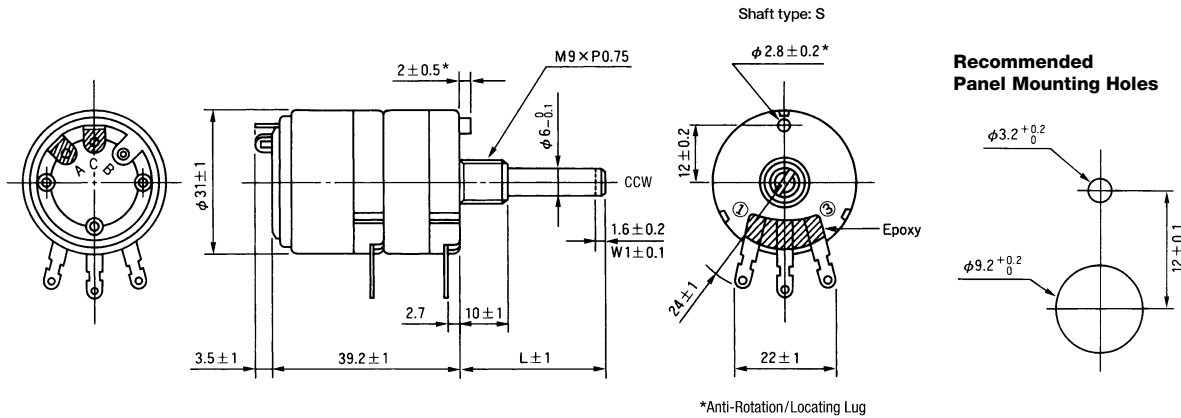

**RV30YT**  
**Panel Mount, Triple Unit, Single Shaft**  
**Right Angle Ear-Lug Terminals on Each Unit**

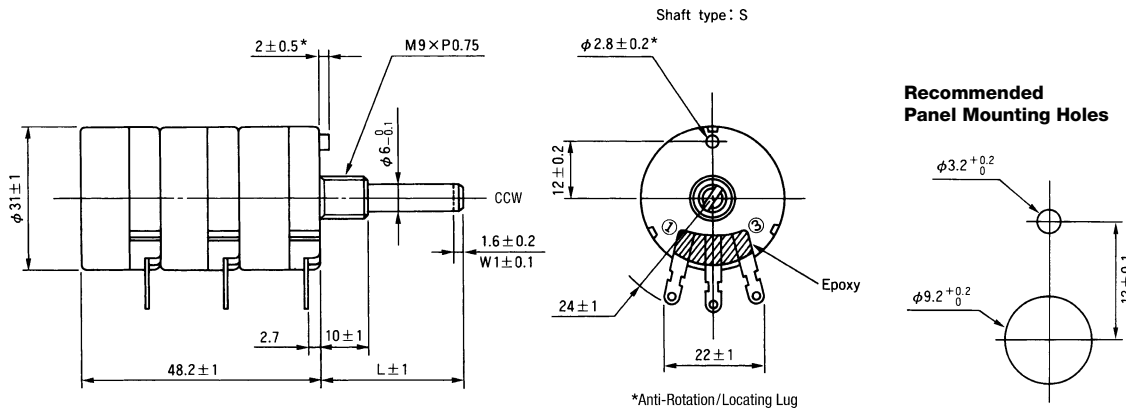

**RV30YD**  
**Panel Mount, Dual Unit, Dual Concentric Shaft**  
**Right Angle Ear-Lug Terminals on Each Unit**

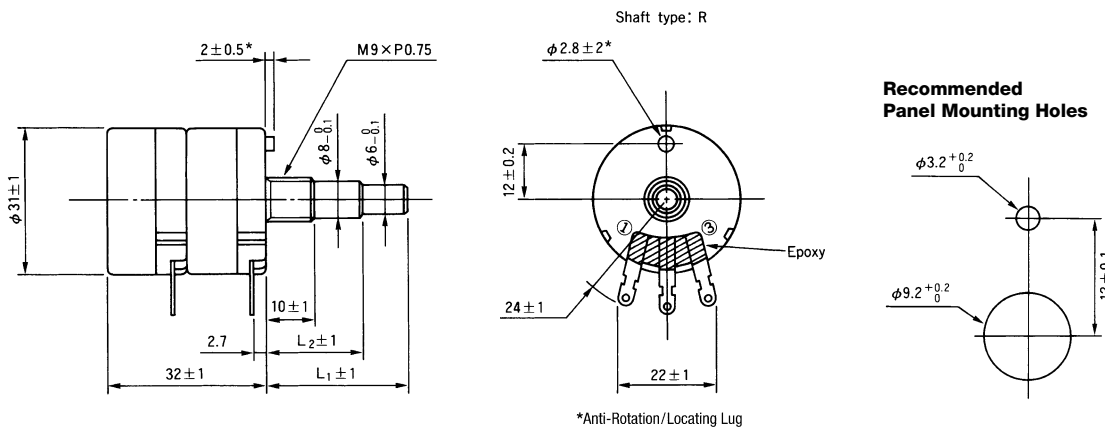

RV 30 Y N ME 20 S B 103 K

NOTE: FMS = From Mounting Surface

- ➔ **Resistance Tolerance: K** = ±10% (standard).
- ➔ **Resistance Code:** Expressed in ohms. A three digit code where the first two digits are significant figures, and the third digit indicates the number of zeros that follow these figures (i.e., 100 = 10Ω; 101 = 100Ω; 102 = 1,000Ω; 103 = 10,000Ω; 105 = 1,000,000Ω). See table for standard resistance values.
- ➔ **For Single Unit:**  
Specify taper and resistance code as shown.
- ➔ **For Ganged Tandem Unit or Dual Unit:**  
Specify a taper code and resistance code for each unit starting with the front unit followed by the rear unit. If both units have the same taper and resistance codes, add "X2" suffix per example below.  
Examples: **B103A503** or if both units are the same: **B103X2**
- ➔ **For Triple Unit:**  
Specify a taper code and resistance code for each unit starting with the front unit followed by the middle and rear units. If all units have the same taper and resistance codes, add "X3" suffix per example below.  
Examples: **B103A503B104** or if all units are the same: **B103X3**
- ➔ **Resistance Taper: B** = Linear.  
**A** = CW Audio (logarithm).  
**C** = CCW Audio (logarithm).
- ➔ **Shaft End Style: S** = Slotted; **F** = Flatted; **R** = Round.
- ➔ **For Single Shaft:**  
Specify the shaft length (FMS) and shaft end style as shown.
- ➔ **For Dual Concentric Shaft:**  
Specify the shaft length (FMS) and shaft end style for the inner shaft followed by the shaft length (FMS) and shaft end style for the outer shaft. Use a dash (-) to separate the code groups for the inner and outer shaft specifications. Example: **30R-20R**
- ➔ **Standard Shaft Length: 15** = 15mm FMS.  
**20** = 20mm FMS.  
Up to 50mm shaft length available (special order).
- ➔ **Switch Type: ME** = SPDT, 110VAC, 1A, Rear Exit Lug Terminals.  
**MF** = SPDT, 110VAC, 3A, Rear Exit Lug Terminals.  
**SE** = SPST, 110VAC, 1A, Rear Exit Lug Terminals.  
**SF** = SPST, 110VAC, 3A, Rear Exit Lug Terminals.  
**Blank** = No Switch.
- ➔ **Style: N** = Panel Mount, Single Unit, Single Shaft, Right Angle Ear-Lug Terminals.  
**L** = Panel Mount, Single Unit, Single Shaft with Shaft Lock, Right Angle Ear-Lug Terminals.  
**G** = Panel Mount, Ganged Tandem Unit, Single Shaft, Right Angle Ear-Lug Terminals on Each Unit.  
**GL** = Panel Mount, Ganged Tandem Unit, Single Shaft with Shaft Lock, Right Angle Ear-Lug Terminals on Each Unit.  
**T** = Panel Mount, Triple Unit, Single Shaft, Right Angle Ear-Lug Terminals on Each Unit.  
**D** = Panel Mount, Dual Unit, Dual Concentric Shaft, Right Angle Ear-Lug Terminals on Each Unit.
- ➔ **Operating Temperature Range: Y** = -10°C to +85°C.
- ➔ **Size: 30** = 30mm Diameter.
- ➔ **TOCOS Series Name: RV** = Carbon Film Element.

Standard Resistance Values and Part Numbering Codes

Standard Nominal Total Resistance Values and Part Numbering Codes

Resistance (Ω)	Code	Resistance (Ω)	Code	Resistance (Ω)	Code	Resistance (Ω)	Code	Resistance (Ω)	Code
100	501	1,000	102	10,000	103	100,000	104	1,000,000	105
200	201	2,000	202	20,000	203	200,000	204	2,000,000	205
500	501	5,000	502	50,000	503	500,000	504	5,000,000	505

Refer to Shaft End Styles Specifications and Hardware Specifications for details and availability.  
For additional information, refer to Guidelines and Precautions for Using Panel Controls.